



TRANE[®]

4TTX5018-SUB-100.00

TAG: _____

SUBMITTAL

NOTE: All dimensions are in mm/inches.

1½ Ton Split System Cooling — 1 Phase 4TTX5018A

Product Specifications

OUTDOOR UNIT ①②	4TTX5018A1000A
POWER CONNS. — V/PH/HZ ③	200/230/1/60
MIN. BRCH. CIR. AMPACITY	11
BR. CIR. } MAX. (AMPS)	15
PROT. RTG. } MIN. (AMPS)	15
COMPRESSOR	CLIMATUFF [®]
NO. USED - NO. SPEEDS	1 - 1
VOLTS/PH/HZ	200/230/1/60
R.L. AMPS ⑦ - L.R. AMPS	6.2 - 38.6
FACTORY INSTALLED	
START COMPONENTS ⑧	YES
INSULATION/SOUND BLANKET	YES
COMPRESSOR HEAT	NO
OUTDOOR FAN	PROPELLER
DIA. (IN.) - NO. USED	27.6 - 1
TYPE DRIVE - NO. SPEEDS	DIRECT - 1
CFM @ 0.0 IN. W.G. ④	3310
NO. MOTORS - HP	1 - 1/3
MOTOR SPEED R.P.M.	850
VOLTS/PH/HZ	200/230/1/60
F.L. AMPS	2.80
OUTDOOR COIL — TYPE	SPINE FIN [™]
ROWS - F.P.I.	1 - 24
FACE AREA (SQ. FT.)	21.99
TUBE SIZE (IN.)	3/8
REFRIGERANT	
LBS. — R-410A (O.D. UNIT) ⑤	6 LBS., 9 OZ.
FACTORY SUPPLIED	YES
LINE SIZE - IN. O.D. GAS ⑥	1/2
LINE SIZE - IN. O.D. LIQ. ⑥	3/8
CHARGING SPECIFICATION	
SUBCOOLING	10°F
DIMENSIONS	H X W X D
CRATED (IN.)	45.4 x 35.1 x 38.7
WEIGHT	
SHIPPING (LBS.)	271
NET (LBS.)	227

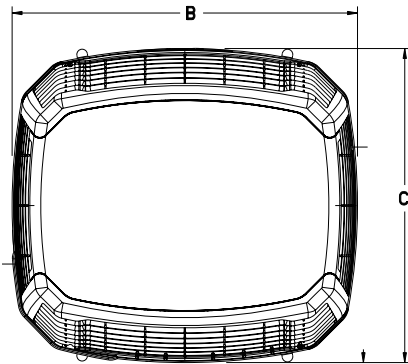

SERVICE PANEL
ELECTRICAL AND REFRIGERANT
COMPONENT CLEARANCES
PER PREVAILING CODES.

UNIT SHOULD BE PLACED SO ROOF
RUN-OFF WATER DOES NOT POUR
DIRECTLY ON UNIT, AND SHOULD BE
AT LEAST 305 (12") FROM WALL AND ALL
SURROUNDING SHRUBBERY ON TWO SIDES,
OTHER TWO SIDES UNRESTRICTED.

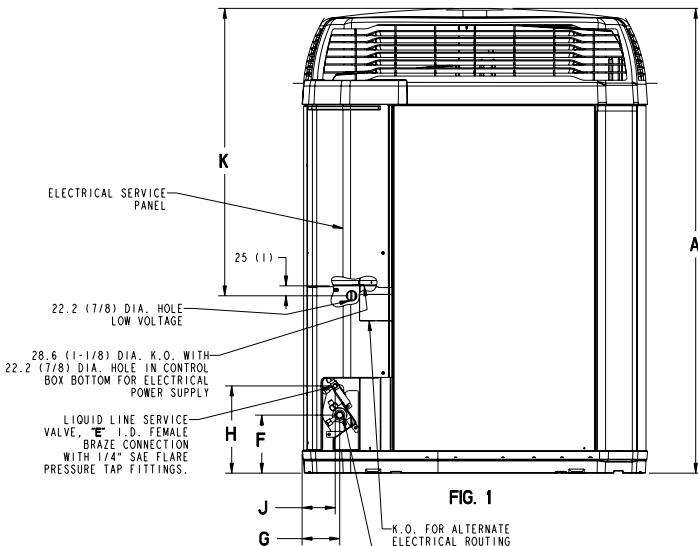

FIG. 1

K.O. FOR ALTERNATE
ELECTRICAL ROUTING

GAS LINE 1/4 TURN BALL SERVICE
VALVE, "D" I.D. FEMALE BRAZED
CONNECTION WITH 1/4" SAE FLARE
PRESSURE TAP FITTING.

From Dwg. 21D152635 Rev. 14

MODELS	BASE	FIG.	A	B	C	D	E	F	G	H	J	K
4TTX5018A	4	1	1064 (41-7/8)	946 (37-1/4)	870 (34-1/4)	1/2	3/8	152 (6)	98 (3-7/8)	219 (8-5/8)	86 (3-3/8)	730 (28-3/4)

- ① Certified in accordance with the Air-Source Unitary Heat Pump Equipment certification program, which is based on ARI standard 210/240.
- ② Rated in accordance with ARI standard 270.
- ③ Calculated in accordance with Natl. Elec. Codes. Use only HACR circuit breakers or fuses.
- ④ Standard Air — Dry Coil — Outdoor
- ⑤ This value approximate. For more precise value see unit nameplate.
- ⑥ Max. linear length 60 ft.; Max. lift - Suction 60 ft.; Max lift - Liquid 60 ft.
For greater length consult refrigerant piping software Pub. No. 32-3312-0*
(* denotes latest revision).
- ⑦ This value shown for compressor RLA on the unit nameplate and on this specification sheet is used to compute minimum branch circuit ampacity and max. fuse size. The value shown is the branch circuit selection current.
- ⑧ No means no start components. Yes means quick start kit components. PTC means positive temperature coefficient starter.

A-weighted Sound Power Level [dB(A)]

MODEL	SOUND POWER LEVEL [dB(A)]	A-WEIGHTED FULL OCTAVE SOUND POWER LEVEL dB - [dB(A)]							
		63	125	250	500	1000	2000	4000	8000
4TTX5018A1	73	51	58	65.3	68.2	64.5	66.4	59	51.6

Mechanical Specification Options

General

The 4TTX5 is fully charged from the factory for up to 15 feet of piping. This unit is designed to operate at outdoor ambient temperatures as high as 115°F. Cooling capacities are matched with a wide selection of air handlers and furnace coils that are A.R.I. certified. The unit is UL listed. Exterior is designed for outdoor application.

Casing

Unit casing is constructed of heavy gauge, G90 galvanized steel and painted with a weather-resistant powder paint on all louvers, panels, prepaint on all other panels. Corrosion and weather-proof CMBP-G30 DuraTuff™ base.

Refrigerant Controls

Refrigeration system controls include condenser fan and compressor contactor. High and low pressure controls are inherent to the compressor. A factory installed liquid line drier is standard.

Compressor

The Climatuff® compressor features a 10 year limited warranty, internal over temperature and pressure protection and total dipped hermetic motor. Other features include: roto lock suction and discharge refrigerant connections, centrifugal oil pump and low vibration and noise.

Condenser Coil

The outdoor coil provides low airflow resistance and efficient heat transfer. The coil is protected on all four sides by louvered panels and has a 10 year limited warranty.

Low Ambient Cooling

As manufactured, this unit has a cooling capability to 55°F. The addition of an evaporator defrost control with TXV permits low ambient cooling to 30° F.

Accessories

Thermostats — Cooling only and heat/cooling (manual and automatic changeover). Sub-base to match thermostat and locking thermostat cover.

Evaporator Defrost Control — See Low Ambient Cooling.



ARI Standard
210/240 UHP

09/07



Trane
A business of
American Standard Companies
www.trane.com

Trane has a policy of continuous product and product data improvement and it reserves the right to change design and specifications without notice.