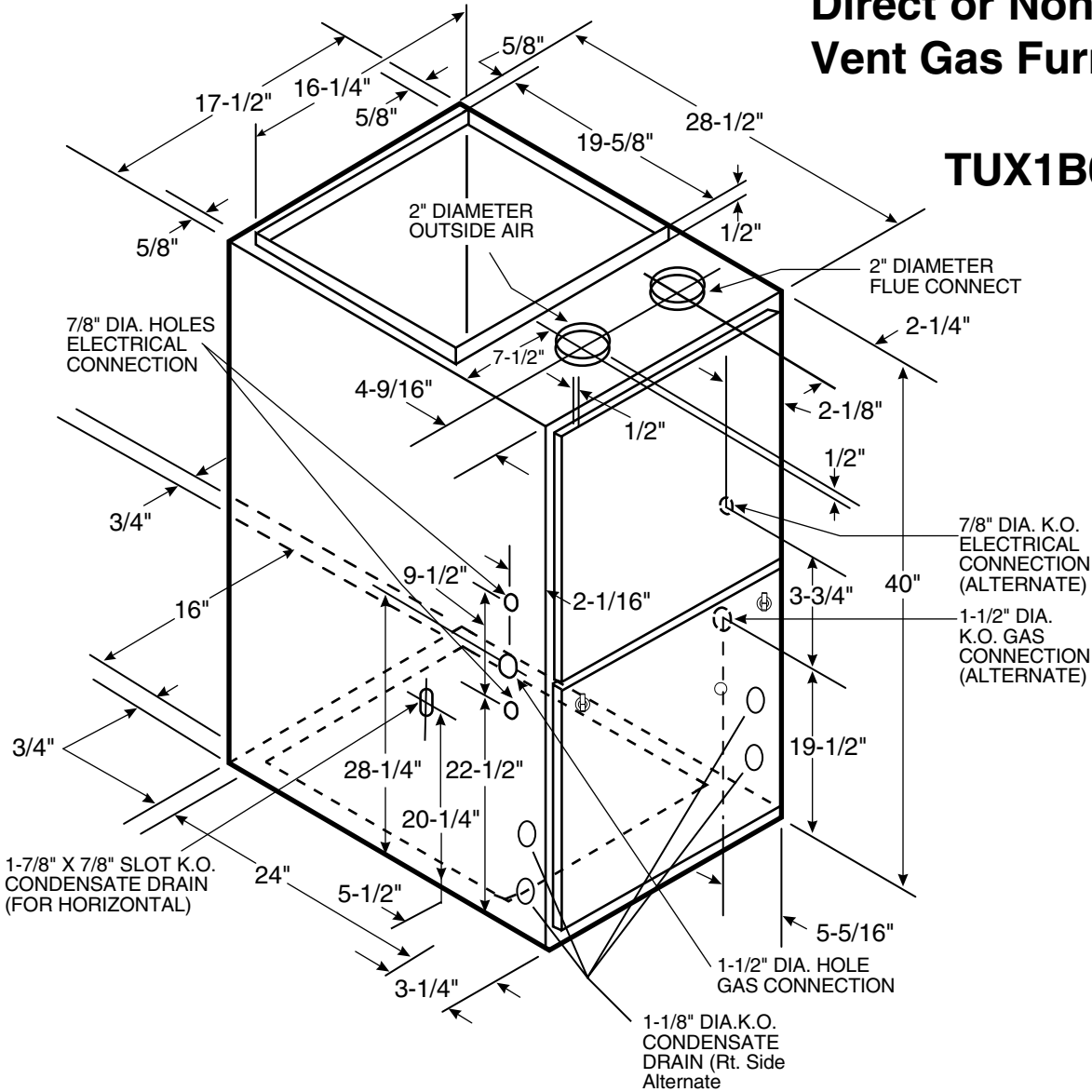

TAG: _____

SUBMITTAL

Upflow / Horizontal Direct or Non-Direct Vent Gas Furnace

TUX1B080A9421A

FURNACE AIRFLOW (CFM) VS. EXTERNAL STATIC PRESSURE (INS. w.g.)

MODEL	SPEED TAP	0.10	0.20	0.30	0.40	0.50	0.60	0.70	0.80	0.90
TUX1B080A9421A	4 - HIGH - Black	1748	1683	1615	1544	1470	1393	1314	1232	1147
	3 - MED-HIGH - Blue	1375	1367	1347	1314	1268	1210	1139	1056	960
	2 - MED-LOW - Yellow	1178	1167	1147	1119	1082	1036	982	919	847
	1 - LOW - Red	859	863	856	839	811	772	723	663	592

CFM VS. TEMPERATURE RISE

MODEL	Cubic Feet Per Minute (CFM)					
	1100	1200	1300	1400	1500	1600
TUX1B080A9421A	61	56	51	48	44	42

General Data ①

TYPE	Upflow / Horizontal
RATINGS ②	
Input BTUH	80,000
Capacity BTUH (ICS) ③	74,000
AFUE	92.1
Temp. rise (Min.-Max.) °F.	35 - 65
BLOWER DRIVE	DIRECT
Diameter-Width (In.)	10 x 8
No. Used	1
Speeds (No.)	4
CFM vs. in. w.g.	See Fan Performance
Motor HP	1/3
R.P.M.	1075
Volts/Ph/Hz	115/1/60
COMBUSTION FAN - Type	Centrifugal
Drive - No. Speeds	Direct - 1
Motor HP - RPM	1/24 - 3200
Volts/Ph/Hz	115/1/60
F.L. Amps	1.35
FILTER — Furnished?	No
Type Recommended	High Velocity
Hi Vel. (No.-Size-Thk.)	1 - 17x25 - 1in.

VENT PIPE DIAMETER — Size (in.)④⑥	2 Round
HEAT EXCHANGER	
Type-Fired	Alum. Steel
-Unfired	
Gauge (Fired)	20
ORIFICES — Main	
Nat.Gas. Qty. — Drill Size	4 — 45
L.P. Gas Qty. — Drill Size	4 — 56
GAS VALVE	Redundant - Single Stage
PILOT SAFETY DEVICE	
Type	Hot Surface Ignition
BURNERS — Type	Multiport Inshot
Number	4
POWER CONN. — V/Ph/Hz ④	115/1/60
Ampacity (In Amps)	9.5
Max. Overcurrent Protection (amps)	15
PIPE CONN. SIZE (IN.)	1/2
DIMENSIONS	H x W x D
Crated (In.)	41- 3/4 x 19-1/2 x 30-1/2
Uncrated (In.)	40 x 17-1/2 x 28
WEIGHT	
Shipping (Lbs.) / Net (Lbs)	158 / 148

Notes

- ① Central Furnace heating designs are certified by AGA and CSA.
- ② For U.S. applications, above input ratings (BTUH) are up to 2,000 feet, derate 4% per 1,000 feet for elevations above 2,000 feet above sea level. For Canadian applications, above input ratings (BTUH) are up to 4,500 feet, derate 4% per 1,000 feet for elevations above 4,500 feet above sea level.
- ③ Based on U.S. government standard tests.
- ④ The above wiring specifications are in accordance with National Electrical Code; however, installations must comply with local codes.
- ⑤ Refer to the Vent Length Table in the Installer's Guide or the Allowable Vent Length label located on the furnace.
- ⑥ All *UX1 and *DX1 furnace models have a vent outlet diameter that equals 2".

Mechanical Specifications

NATURAL GAS MODELS—Central heating furnace designs are certified by the American Gas Association for both natural and L.P. gas. Limit setting and rating data were established and approved under standard rating conditions using American National Standards Institute standards.

SAFE OPERATION — The Integrated System Control has solid state devices, which continuously monitor for presence of flame, when the system is in the heating mode of operation. Slow opening, dual solenoid combination gas valve and regulator provide extra safety and quieter operation.

QUICK HEATING—Durable, cycle tested, heavy gauge **aluminized steel heat exchanger and stainless steel secondary heat exchanger** quickly transfer over 90% of the heat to provide warm conditioned air to the structure. **Low energy power vent blower**, to increase efficiency and provide a positive discharge of gas fumes to the outside as it draws outdoor air in for sealed combustion, which means it uses no indoor air for combustion.

BURNERS — Multi-port, in-shot burners will give years of quiet and efficient service. All models can be converted to **L.P. gas** without changing burners.

INTEGRATED SYSTEM CONTROL—Exclusively designed operational program provides total control of furnace limit sensors, blowers, gas valve, flame control and includes self diagnostics for ease of service. The built-in, selectable "**Cooling Fan Off**" feature provides time-delay capability like a BAY24X045 Time-Delay Kit for cooling operation. Also contains connection points for E.A.C./humidifier.

AIR DELIVERY — The multispeed, direct-drive blower motor, with sufficient airflow range for most heating and cooling requirements, will switch from heating to cooling speeds on demand from room thermostat. The blower door safety switch will prevent or terminate furnace operation when the blower door is removed. (Fan relay and 35VA control transformer is standard).

STYLING — **Heavy gauge steel and "wraparound" cabinet construction** is used in the cabinet with baked-on enamel finish for strength and beauty. The heat exchanger section of the cabinet is completely lined with foil-faced fiberglass insulation. This results in quiet and efficient operation due to the excellent acoustical and insulating qualities of fiberglass.

FEATURES AND GENERAL OPERATION — These High Efficiency, Direct Vent, Condensing Gas Furnaces employ a Hot Surface Ignition system, which eliminates the waste of a constantly burning pilot. They are convertible for HORIZONTAL use by rotating the unit to its left side. The integrated system control lights the main burners upon a demand for heat from the room thermostat. Complete front service access.

- a. Low energy power venter.
- b. Vent proving differential switch.

Since Trane has a policy of continuous product and product data improvement, it reserves the right to change specifications and design without notice.

Technical Literature - Printed in U.S.A.

Trane
6200 Troup Highway
Tyler, TX 75707



Library	Unitary
Product Section	Furnaces
Product	Furnace
Model	TUX1
Literature Type	Submittal
Sequence	-
Date	09/08
File No.	TUX1B080A-SUB-2A
Supersedes	TUX1B080A-SUB-2